



411 BURNHAM ST.  
 P.O. BOX 280186  
 EAST HARTFORD, CT 06108  
 TEL (860) 289-0285 FAX (860) 282-1487  
 TOLL FREE 1-800-969-0285

# HEAVY WELDED STEEL BRACKET

EMPIRE INDUSTRIES, INC. FIG. #802  
 ERICO FIG. #353  
 TOLCO FIG. #30H

**MATERIAL:** CARBON STEEL

**FINISH:**  PLAIN  ELECTRO-GALVANIZED  
 HOT-DIPPED GALVANIZED  PAINTED

**SERVICE:** RECOMMENDED FOR SUPPORT OF PIPE LOADS UP TO 3000 LBS. CONSTRUCTED OF FACING ANGLE IRON WITH 1" SPACE. THE BRACKET PROVIDES MAXIMUM LATERAL ADJUSTMENT WHEN CARRYING OR SUSPENDING PIPE.

**APPROVALS:** COMPLIES WITH FEDERAL SPECIFICATION WW-H-171-E (TYPE# 34), A-A-1192A (TYPE# 33), AND MANUFACTURERS' STANDARDIZATION SOCIETY MSS SP 58 AND SP 69 (TYPE#33).

**ORDERING:** SPECIFY SIZE NUMBER, FIGURE NUMBER AND FINISH.

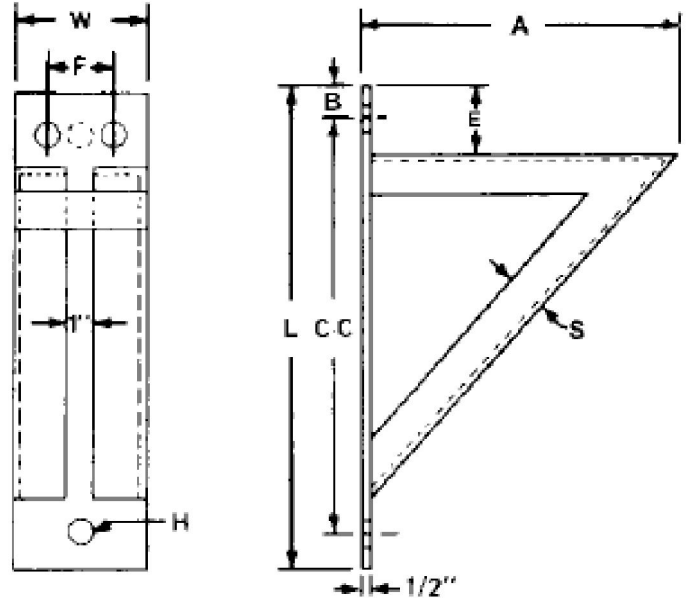

SIZE No.	C-C	A	F	E	H	B	L	ANGLE SIZE S	W	WGT EACH (LBS)
1	15 1/4	12	ONE HOLE	2 3/4	13/16	1 1/2	18	2 x 1 1/2 x 1/4	4	25.00
2	21 3/8	18	2 3/4	2 3/4	15/16	1 3/8	24	2 x 2 x 1/4	5	38.00
3	27 1/2	24	2 3/4 2 1/2	2 3/4	1 1/16	1 1/4	30	2 1/2 x 2 x 5/16	5	69.00
4	33 1/4	30	2 1/2	3	1 1/16	1 1/2	36	2 1/2 x 2 x 5/16	5	82.10
5	39	36	3 1/2	3	1 1/16	1 1/2	42	3 1/2 x 2 1/2 x 3/8	6	130.00
6	46	42	3 1/2	3 1/2	1 1/16	2	50	3 1/2 x 2 1/2 x 3/8	6	155.00

### SUBMITTAL INFORMATION

CUSTOMER:		APPROVAL STAMP	
PROJECT NAME:			
PROJECT NUMBER:	SECTION:		
PARAGRAPH:	OTHER:		

REV: A

2008