



411 BURNHAM ST.
 P.O. BOX 280186
 EAST HARTFORD, CT 06108
 TEL (860) 289-0285 FAX (860) 282-1487
 TOLL FREE 1-800-969-0285

LIGHT WELDED STEEL BRACKET & CLIP

NEFCO FIG #N194

NEFCO FIG #N194C

EMPIRE INDUSTRIES, INC. FIG. #820 & 820C
 ERICO FIG. #348
 TOLCO FIG. #30

MATERIAL: CARBON STEEL

FINISH: PLAIN ELECTRO-GALVANIZED HOT DIP GALVANIZED PAINTED

SERVICE: RECOMMENDED FOR THE SUSPENSION OF HANGER ROD FOR SUPPORT OF LIGHT LOADS UP TO 750 LBS. ROD CAN BE SUSPENDED AT ANY POINT ALONG THE LENGTH OF THE BRACKET, THUS PROVIDING HORIZONTAL ADJUSTMENT, USING FIGURE #820C CLIP WHICH CONSISTS OF TWO STEEL PLATES JOINED BY A BOLT AND NUT IN ONE END.

APPROVALS: FIG. 194 COMPLIES WITH FEDERAL SPECIFICATION WW-H-171E (TYPE #32), A-A-1192 A (TYPE# 31) AND MANUFACTURERS' STANDARDIZATION SOCIETY MSS SP 58 AND SP 69 (TYPE# 31).

ORDERING: SPECIFY SIZE NUMBER, FIGURE NUMBER AND FINISH.

NOTES: PIPING SUSPENDED FROM FIG. 194C CLIP SHALL NOT EXCEED 3 1/2" IN DIAMETER. SIDE CLIP (FIG. 194C) TO BE ORDERED SEPARATELY.

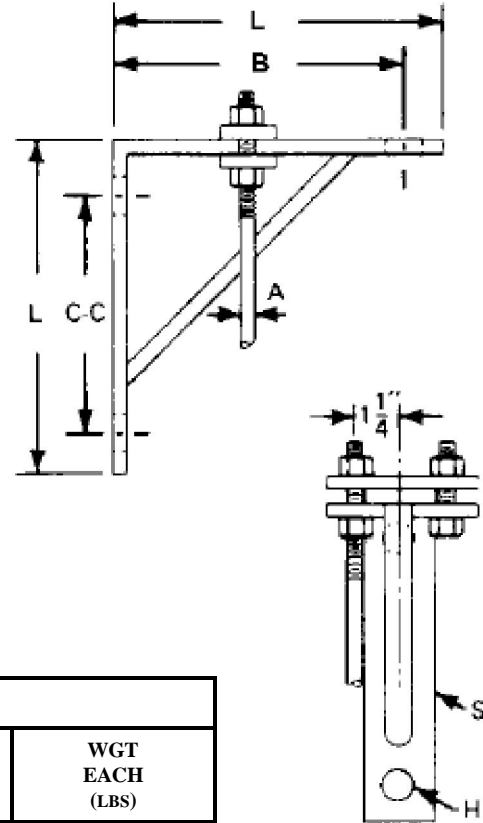

FIG. 194						
BRACKET SIZE	B	C-C	HOLES H	L	STOCK SIZE S	WGT EACH (LBS)
1	8	6 1/2	13/16	9	2 X 3/8	4.20
2	12	10 1/2	13/16	13	2 X 3/8	6.50
3	18	16 1/2	13/16	19	2 X 3/8	9.40

FIG. 194C			
CLIP NUMBER	PIPE SIZE	ROD SIZE A	WGT EACH (lbs)
1	3/4 to 2	3/8	0.80
2	2 1/2 to 3 1/2	1/2	1.24

SUBMITTAL INFORMATION	
CUSTOMER:	APPROVAL STAMP
PROJECT NAME:	<div style="border: 1px solid black; width: 100%; height: 100%;"></div>
PROJECT NUMBER:	
SECTION:	
PARAGRAPH:	OTHER: