



411 BURNHAM ST.
 P.O. BOX 280186
 EAST HARTFORD, CT 06108
 TEL (860) 289-0285 FAX (860) 282-1487
 TOLL FREE 1-800-969-0285

HEAVY BEAM CLAMP ASSEMBLY NEFCO FIG #N292S EMPIRE INDUSTRIES, INC. FIG. #450

MATERIAL: ASTM A-36 CARBON STEEL WITH ASTM A-235 CLASS C EYE-NUT.

FINISH: PLAIN ELECTRO-GALVANIZED PAINTED

SERVICE: DESIGNED TO BE USED FOR THE SUSPENSION OF HEAVY LOADS FROM BEAMS UP TO 16 INCHES WIDE AND UP TO 1 INCH THICK. NORMALLY USED WITH FIGURE 26, 26W EYERODS OR FIGURE 13, 13I WELDLESS EYE NUTS.

APPROVALS: COMPLIES WITH FEDERAL SPECIFICATION WW-H-171-E (TYPE#28 WITHOUT LINKS, TYPE #29 WITH LINKS), A-A1192A (TYPE#28 WITHOUT LINKS, TYPE #29 WITH LINKS) AND MANUFACTURERS' STANDARDIZATION SOCIETY MSS SP-58 AND SP-69 (TYPE# 28 WITHOUT LINKS, TYPE #29 WITH LINKS).

ORDERING: SPECIFY CLAMP SIZE, FIGURE NUMBER, ROD SIZE AND FINISH.

NOTES: MAXIMUM LOADS ARE BASED ON MAXIMUM ROD SIZES.

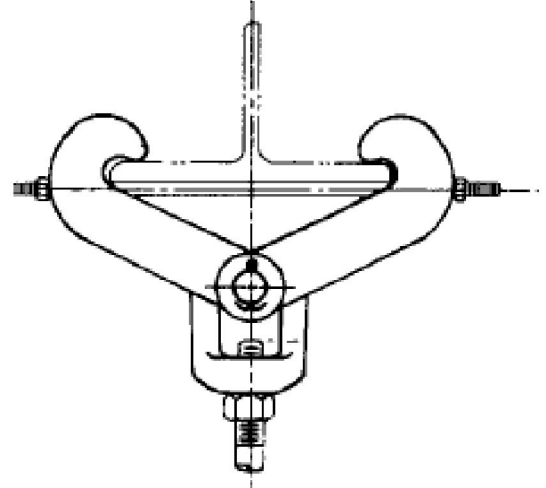

SIZE	FLANGE SIZE		MAX ROD	WGT EACH (lbs)	MAX LOAD (lbs)
	WIDTH	MAX THICKNESS			
1	3-8	5/8	3/4	8	2800
2	7-12*	5/8	3/4	12	2800
3	3-8	3/4	1	11	5000
4	7-15	3/4	1	16	5000
5	5-11	1	1 1/2	30	11500
6	8-16*	1	1 1/2	48	11500
*SUPPLIED WITH LINKS					

SUBMITTAL INFORMATION

CUSTOMER:		APPROVAL STAMP	
PROJECT NAME:			
PROJECT NUMBER:	SECTION:		
PARAGRAPH:	OTHER:		