



411 BURNHAM ST.
 P.O. BOX 280186
 EAST HARTFORD, CT 06108
 TEL (860) 289-0285 FAX (860) 282-1487
 TOLL FREE 1-800-969-0285

RISER CLAMPS COPPER-GARD

EMPIRE INDUSTRIES, INC. FIG. #50CTI
 ERICO FIG. #511
 TOLCO FIG. #6F

MATERIAL: CARBON STEEL

FINISH: COPPER-GARD - IS A THREE-STEP PROCESS, THAT APPLIES A BAKED-ON EPOXY PAINT. THE PARTS ARE ZINC PLATED TO .0002" THICK, AN EPOXY COPPER COLORED POWDER IS THEN APPLIED BY AN ELECTROSTATIC METHOD, AND FINALLY, THE COATED PARTS ARE BAKED AT 180 DEGREES FOR 20 MINUTES.

SERVICE: DESIGNED FOR SUPPORTING AND STABILIZING VERTICAL TUBING RUNS.

APPROVALS: COMPLIES WITH FEDERAL SPECIFICATION WW-H-171-E (TYPE # 8), A-A-1192A (TYPE# 8), MANUFACTURERS' STANDARDIZATION SOCIETY SP-58 AND MSS SP-69 (TYPE# 8).

ORDERING: SPECIFY PIPE SIZE, FIGURE NUMBER AND FINISH.

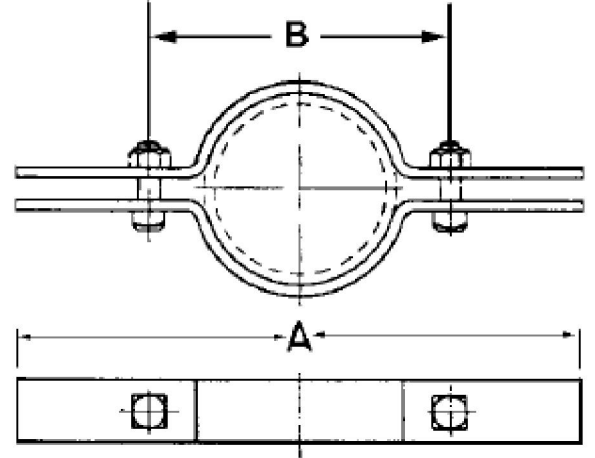

PIPE SIZE	TUBE OD	MATERIAL SIZE	BOLT	A	B	WGT EACH (LBS)	MAX REC LOAD (LBS)
1/2	0.625	11ga x 1.0	1/4	6 11/16	1 11/16	0.48	225
3/4	0.875	11ga x 1.0	1/4	7	2	0.50	225
1	1.125	11ga x 1.0	1/4	8 3/4	2 1/4	0.64	250
1 1/4	1.375	11ga x 1.0	1/4	9	2 1/2	.066	250
1 1/2	1.625	11ga x 1.0	1/4	9 3/8	2 7/8	0.68	250
2	2.125	8ga x 1.0	3/8	9 15/16	3 3/8	1.06	500
2 1/2	2.625	8ga x 1.0	3/8	10 1/2	4	1.08	500
3	3.125	8ga x 1.0	3/8	11	4 7/16	1.16	500
3 1/2	3.625	8ga x 1.25	3/8	12 3/16	5 1/8	1.58	500
4	4.125	8ga x 1.25	3/8	12 5/8	5 9/16	1.66	500
5	5.125	3ga x 1.50	1/2	14 1/8	7 1/8	3.42	815
6	6.125	3ga x 1.50	1/2	15	8	3.76	815

SUBMITTAL INFORMATION

CUSTOMER:		APPROVAL STAMP
PROJECT NAME:		
PROJECT NUMBER:	SECTION:	
PARAGRAPH:	OTHER:	