



411 BURNHAM ST.
 P.O. BOX 280186
 EAST HARTFORD, CT 06108
 TEL (860) 289-0285 FAX (860) 282-1487
 TOLL FREE 1-800-969-0285

LIGHT DUTY SPOT INSERTS

EMPIRE INDUSTRIES, INC. FIG. #81
 ERICO FIG. #355
 TOLCO FIG. #310

MATERIAL: STEEL

STANDARD FINISH: PLAIN ELECTRO-PLATED

SERVICE: DESIGNED TO BE EMBEDDED IN CONCRETE TO ATTACH
 1/4-20 TO 7/8-9 HANGER RODS.

HOW TO INSTALL: ATTACH CONCRETE INSERT TO FORMS AND
 INSTALL REINFORCING RODS AS REQUIRED. AFTER FORMS ARE
 DISMANTLED, THE KNOCKOUT CAN BE REMOVED FROM THE INSERT.
 THE INSERT NUT CAN BE INSTALLED AND THE ROD FASTENED TO THE
 NUT. THE ROD SHOULD TOUCH THE INSIDE TOP OF THE INSERT BUT
 SHOULD NOT BE FORCED FURTHER TO AVOID DAMAGING THE INSERT.

WEIGHT: WT./C 46 LBS. (20.8 KG)

APPROVALS: UNDERWRITERS' LABORATORIES LISTED AND FACTORY
 MUTUAL APPROVED FOR MAXIMUM PIPE SIZE 6" (150).
 COMPLIES WITH FEDERAL SPECIFICATION WW-H- 171E TYPE 19
 AND MANUFACTURERS' STANDARDIZATION SOCIETY SP-69 &
 SP-58 TYPE 18.

DESIGN LOAD: LOADING BASED ON A STRAIGHT PULL OF 800 LBS.
 (3.56 kN).

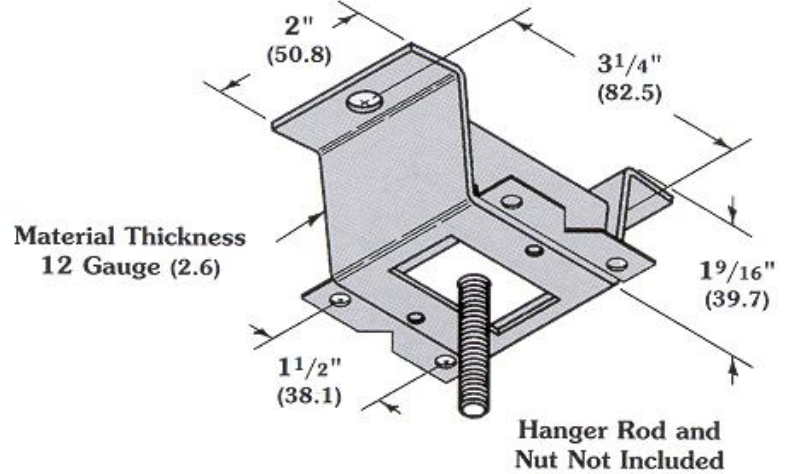

SUBMITTAL INFORMATION

CUSTOMER:		APPROVAL STAMP
PROJECT NAME:		
PROJECT NUMBER:	SECTION:	
PARAGRAPH:	OTHER:	

REV: A

2009