



411 BURNHAM ST.
P.O. BOX 280186
EAST HARTFORD, CT 06108
TEL (860) 289-0285 FAX (860) 282-1487
TOLL FREE 1-800-969-0285

PS 1200 O.D. TUBING CLAMP 316 STAINLESS STEEL



MATERIAL: POWER-STRUT PIPE, CONDUIT AND O.D. TUBING CLAMPS ARE MADE ON PUNCH PRESS DIES FROM HOT ROLLED, PICKLED AND OILED STEEL WHICH CONFORMS TO THE ASTM A-366, A-570, A-575 AND A-576 STANDARDS. SELECT SIZES OF O.D. TUBING CLAMPS ARE AVAILABLE IN STAINLESS STEEL OR ALUMINUM.

STANDARD FINISH: ALL STEEL CLAMPS ARE ELECTRO-GALVANIZED. SELECT SIZES OF O.D. TUBING CLAMPS ARE AVAILABLE IN COPPER PLATED FINISH. PVC COATINGS ARE AVAILABLE UPON SPECIAL REQUEST.

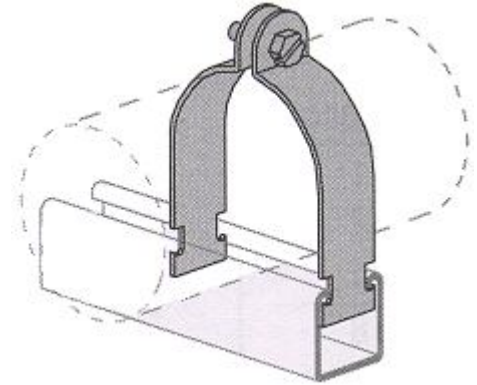

O.D. SIZE	STOCK THICKNESS	HANGING LOAD RATING/LBS.	WT./ 100 PCS	OTHER FINISHES AVAILABLE
1/4	.060	400	8	
3/8	.060	400	8	CPLT
1/2	.060	400	9	CPLT
5/8	.060	400	10	CPLT
3/4	.060	400	11	
7/8	.060	400	12	CPLT
1	.075	600	14	
1 1/8	.075	600	15	SS CPLT
1 1/4	.075	600	16	SS
1 3/8	.075	600	17	SS CPLT
1 1/2	.075	600	18	SS
1 5/8	.075	600	19	SS CPLT
1 3/4	.105	800	29	SS
1 7/8	.105	800	28	SS
2	.105	800	31	SS
2 1/8	.105	800	32	SS CPLT
2 1/4	.105	800	33	SS
2 3/8	.105	800	34	SS
2 1/2	.105	800	35	SS
2 5/8	.105	800	37	SS CPLT
2 3/4	.105	800	38	SS
2 7/8	.105	800	40	SS
3	.105	800	41	SS
3 1/8	.105	800	43	SS CPLT
3 1/4	.105	800	45	SS
3 3/8	.105	800	46	SS
3 1/2	.105	800	47	SS
3 5/8	.105	800	56	SS CPLT
3 3/4	.105	800	58	SS
3 7/8	.125	1,000	60	SS
4	.125	1,000	62	SS
4 1/8	.125	1,000	62	SS CPLT
4 1/4	.125	1,000	64	SS
4 3/8	.125	1,000	66	SS
4 1/2	.125	1,000	67	SS

O.D. SIZE	STOCK THICKNESS	HANGING LOAD RATING/LBS.	WT./ 100 PCS
4 5/8	.125	1,000	70
4 3/4	.125	1,000	72
4 7/8	.125	1,000	73
5	.125	1,000	74
5 1/8	.125	1,000	76
5 1/4	.125	1,000	77
5 3/8	.125	1,000	78
5 1/2	.125	1,000	79
5 5/8	.135	1,000	88
5 3/4	.135	1,000	90
5 7/8	.135	1,000	92
6	.135	1,000	94
6 1/8	.135	1,000	96
6 1/4	.135	1,000	98
6 3/8	.135	1,000	99
6 1/2	.135	1,000	100
6 5/8	.135	1,000	102
6 3/4	.135	1,000	104
6 7/8	.135	1,000	106
7	.135	1,000	108
7 1/8	.135	1,000	110
7 1/4	.135	1,000	112
7 3/8	.135	1,000	114
7 1/2	.135	1,000	116
7 5/8	.135	1,000	117
7 3/4	.135	1,000	119
7 7/8	.135	1,000	121
8	.135	1,000	123
8 1/8	.135	1,000	125
8 1/4	.135	1,000	126
8 3/8	.135	1,000	128
8 1/2	.135	1,000	129
8 5/8	.135	1,000	130

SUBMITTAL INFORMATION

CUSTOMER:		APPROVAL STAMP
PROJECT NAME:		
PROJECT NUMBER:	SECTION:	
PARAGRAPH:	OTHER:	