



PS 2522 FOUR-WHEEL TROLLEY

411 BURNHAM ST.
P.O. BOX 280186
EAST HARTFORD, CT 06108
TEL (860) 289-0285 FAX (860) 282-1487
TOLL FREE 1-800-969-0285



MATERIAL: ALL POWER-STRUT FITTINGS ARE FORMED IN PUNCH PRESS DIES FROM MILD, PICKLED AND OILED, BAR OR STRIP STEEL. PLAIN OR ELECTRO-GALVANIZED FITTINGS MEET THE REQUIREMENTS FOR ASTM A575 AND A-576, OR ASTM A-36. CARBON STEEL WHEELS HAVE STAINLESS BALL BEARINGS.

STANDARD DIMENSIONS: STANDARD DIMENSIONS ON ALL FITTINGS ARE AS FOLLOWS EXCEPT WHERE OTHERWISE INDICATED.

FITTING THICKNESS: 1/4"
FITTING WIDTH: 1 5/8"
HOLE DIAMETER: 9/16"
HOLE SPACING: 1 7/8" ON CENTERS AND 13/16" FROM ENDS.

STANDARD FINISH: PAINTED GREEN ELECTRO-GALVANIZED

ORDERING INFORMATION: WHEN ORDERING, ADD THE LENGTH OR SIZE AND FINISH TO THE PART NUMBER.

LOAD RATING: 600 LBS.

USE WITH: PS 200

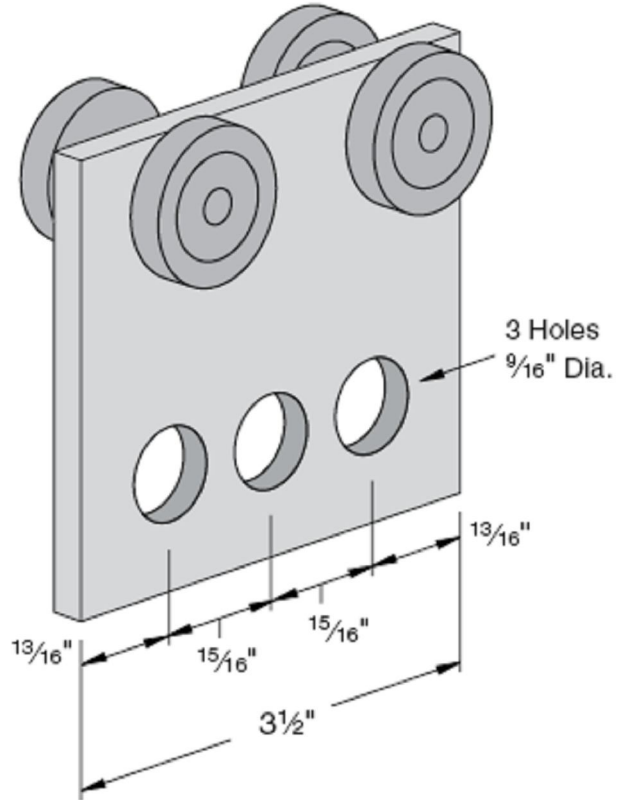

Weight/100 pcs: 110 lbs.

SUBMITTAL INFORMATION

CUSTOMER:		APPROVAL STAMP
PROJECT NAME:		
PROJECT NUMBER:	SECTION:	
PARAGRAPH:	OTHER:	

REV: A

2008