



# PS 3126 ONE-PIECE PIPE STRAP

411 BURNHAM ST.  
P.O. BOX 280186  
EAST HARTFORD, CT 06108  
TEL (860) 289-0285 FAX (860) 282-1487  
TOLL FREE 1-800-969-0285



**MATERIAL:** POWER-STRUT PIPE, CONDUIT AND O.D. TUBING CLAMPS ARE MADE ON PUNCH PRESS DIES HOT ROLLED, PICKLED AND OILED STEEL WHICH CONFORMS TO THE ASTM A-1008, A-1011 SS, A-575 AND A-576 STANDARDS. SELECT SIZES OF O.D. TUBING CLAMPS ARE AVAILABLE IN STAINLESS STEEL OR ALUMINUM. SS MATERIAL IN ACCORDANCE WITH ASTM A 240 (TYPE 304 OR TYPE 316).

**STANDARD FINISH:** ALL STEEL CLAMPS ARE ELECTRO-GALVANIZED. SELECT SIZES OF O.D. TUBING CLAMPS ARE AVAILABLE IN COPPER PLATED FINISH. PVC COATING ARE AVAILABLE UPON SPECIAL REQUEST.

**ORDERING INFORMATION:** WHEN ORDERING, ADD THE LENGTH OR SIZE AND FINISH TO THE PART NUMBER.

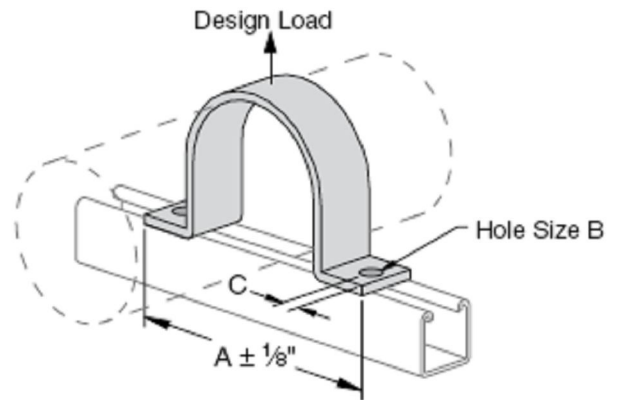

PIPE SIZE	A	B	C	DESIGN LOAD	WT./ 100 pcs.
1/2"	2 7/8"	9/32"	7/16"	500	23
3/4"	3 1/8"	9/32"	7/16"	500	26
1"	3 3/8"	9/32"	7/16"	500	31
1 1/4"	3 3/4"	9/32"	7/16"	500	35
1 1/2"	3 7/8"	9/32"	7/16"	500	39
2"	5 3/4"	7/16"	11/16"	1,000	94
2 1/2"	6 1/4"	7/16"	11/16"	1,000	114
3"	6 7/8"	7/16"	11/16"	1,000	133
3 1/2"	7 3/8"	7/16"	11/16"	1,000	152
4"	7 7/8"	7/16"	11/16"	1,000	176
5"	9"	7/16"	11/16"	1,000	198
6"	10"	7/16"	11/16"	1,000	225

### SUBMITTAL INFORMATION

CUSTOMER:		APPROVAL STAMP
PROJECT NAME:		
PROJECT NUMBER:	SECTION:	
PARAGRAPH:	OTHER:	

REV: A

2008