



# PS 500 - STRUT CHANNEL (1 5/8 x 13/16 x 14 GA.)

411 BURNHAM ST.  
P.O. BOX 280186  
EAST HARTFORD, CT 06108  
TEL (860) 289-0285 FAX (860) 282-1487  
TOLL FREE 1-800-969-0285



**FINISH:**  PLAIN  PRE-GALVANIZED  PAINTED GREEN  
 PVC COATED (BLACK POLY VINYL CHLORIDE RESIN COATED TO A MAX THICKNESS OF 20 MILS)

**STOCK LENGTH:** 10' AND 20', OTHER LENGTHS ON REQUEST.

**NOTES:** COLUMN LOADS ARE FOR ALLOWABLE AXIAL LOADS AND MUST BE REDUCED FOR ECCENTRIC LOADING. FOR CONCENTRATED LOAD AT CENTER OF SPAN, DIVIDE UNIFORM LOAD BY 2 AND MULTIPLY CORRESPONDING DEFLECTION BY 0.8. THE TABLE BELOW IS BASED ON A SOLID CHANNEL SECTION.

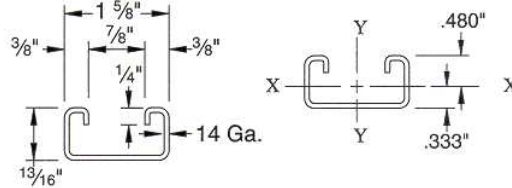

WEIGHT (IBS./100 FT.)	AREA OF SECTION	X-X AXIS			Y-Y AXIS		
		MOMENT OF INERTIA (INCH <sup>4</sup> )	SECTION MODULUS (INCH <sup>3</sup> )	RADIUS OF GYRATION (INCH)	MOMENT OF INERTIA (INCH <sup>4</sup> )	SECTION MODULUS (INCH <sup>3</sup> )	RADIUS OF GYRATION (INCH)
98	0.287	0.025	0.053	0.298	0.106	0.131	0.609

**MODULUS OF ELASTICITY: 29,000,000 PSI**

SPAN, OR COLUMN IN	MAX. LOAD OF COLUMN LOADED AT C.G. (K=1.0) LBS	STATIC BEAM LOAD (X-X AXIS)			
		TOTAL UNIFORM LOAD @25,000 PSI LBS	DEFLECTION @25,000 PSI IN	TOTAL UNIFORM LOAD @ 1/240 SPAN DEFLECTION LBS	TOTAL UNIFORM LOAD @ 1/360 SPAN DEFLECTION LBS
12	5,860	890	0.03	-	-
18	5,450	590	0.06	-	490
24	4,810	440	0.11	410	270
30	3,980	360	0.17	260	170
36	2,980	300	0.24	180	120
42	2,190	250	0.33	130	90
48	1,680	220	0.43	100	70
54	1,330	200	0.55	80	50
60	-	180	0.68	70	40
66	-	160	0.82	50	40
72	-	150	0.98	50	30
84	-	130	1.33	30	20
96	-	110	1.74	30	20
108	-	100	2.20	20	10
120	-	90	2.71	20	10

FOR PIERCED BEAM CHANNELS, REDUCE BEAM LOAD VALUES AS FOLLOWS:	
PS-500-EH	15%
PS-500-S	15%
PS-500-H	10%

### PS 500 - Crush Loads

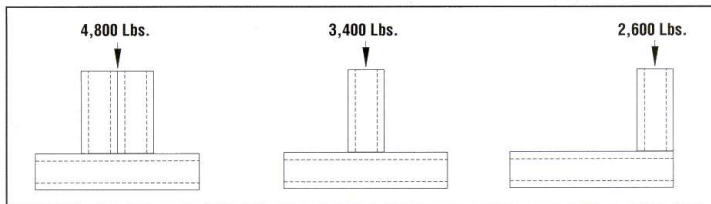

**Resistance to Slip** - 1,000 lbs. per bolt when 1/2" PS NS channel nuts are used.

**Pull Out Strength** - 1,400 lbs. per bolt when 1/2" PS NS channel nuts are used.

### PS 500 EH - Channel with Elongated Holes

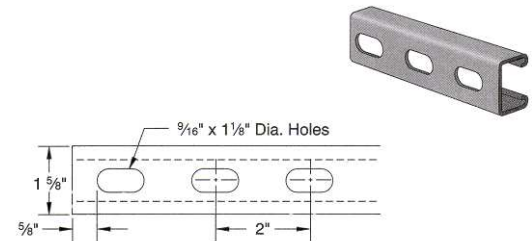

Weight: 87 lbs./100 ft.

### SUBMITTAL INFORMATION

CUSTOMER:		APPROVAL STAMP	
PROJECT NAME:			
PROJECT NUMBER:	SECTION:		
PARAGRAPH:	OTHER:		



# PS 200 - STRUT CHANNEL

## (1 5/8 x 1 5/8 x 12 GA.)

411 BURNHAM ST.  
 P.O. BOX 280186  
 EAST HARTFORD, CT 06108  
 TEL (860) 289-0285 FAX (860) 282-1487  
 TOLL FREE 1-800-969-0285



**FINISH:**  PLAIN  PRE-GALVANIZED  PAINTED GREEN  PVC COATED (BLACK POLY VINYL CHLORIDE RESIN COATED TO A MAX THICKNESS OF 20 MILS)

**STOCK LENGTH:** 10' AND 20', OTHER LENGTHS ON REQUEST.

**NOTES:** COLUMN LOADS ARE FOR ALLOWABLE AXIAL LOADS AND MUST BE REDUCED FOR ECCENTRIC LOADING. FOR CONCENTRATED LOAD AT CENTER OF SPAN, DIVIDE UNIFORM LOAD BY 2 AND MULTIPLY CORRESPONDING DEFLECTION BY 0.8. THE TABLE BELOW IS BASED ON A SOLID CHANNEL SECTION.

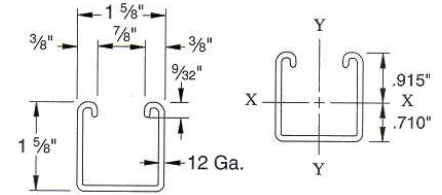
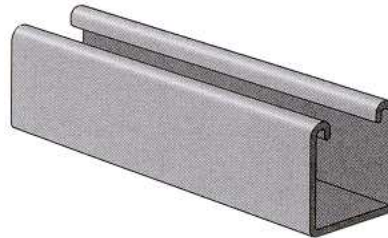

WEIGHT (IBS./100 FT.)	AREA OF SECTION (INCH <sup>2</sup> )	X-X AXIS			Y-Y AXIS		
		MOMENT OF INERTIA (INCH <sup>4</sup> )	SECTION MODULUS (INCH <sup>3</sup> )	RADIUS OF GYRATION (INCH)	MOMENT OF INERTIA (INCH <sup>4</sup> )	SECTION MODULUS (INCH <sup>3</sup> )	RADIUS OF GYRATION (INCH)
176	0.519	0.176	0.192	0.581	0.222	0.273	0.654

**MODULUS OF ELASTICITY: 29,000,000 PSI**

SPAN, OR COLUMN IN	MAX. LOAD OF COLUMN LOADED AT C.G. (K=1.0) LBS	STATIC BEAM LOAD (X-X AXIS)			
		TOTAL UNIFORM LOAD @25,000 PSI LBS	DEFLECTION @25,000 PSI IN	TOTAL UNIFORM LOAD @1/240 SPAN DEFLECTION LBS	TOTAL UNIFORM LOAD @ 1/360 SPAN DEFLECTION LBS
12	10,580	3230	0.01	-	-
18	9,720	2150	0.03	-	-
24	8,670	1610	0.06	-	-
30	7,530	1290	0.09	-	1,230
36	6,360	1080	0.13	-	850
42	5,240	920	0.17	-	630
48	4,420	810	0.22	720	480
54	3,830	720	0.28	570	380
60	3,390	650	0.35	460	310
66	3,040	590	0.42	380	250
72	2,760	540	0.50	320	210
84	2,310	460	0.69	230	160
96	1,980	400	0.90	180	120
108	1,710	360	1.14	140	90
120	-	320	1.40	120	80

FOR PIERCED CHANNELS, REDUCE BEAM LOAD VALUES AS FOLLOWS:	
PS-200-EH	15%
PS-200-S	15%
PS-200-H	10%
PS-200-K06	5%
PS-200-SB	30%

FOR EXTRUDED ALUMINUM  
CHANNELS REDUCE BEAM  
LOAD VALUES 38%

### PS 200 - Crush Loads

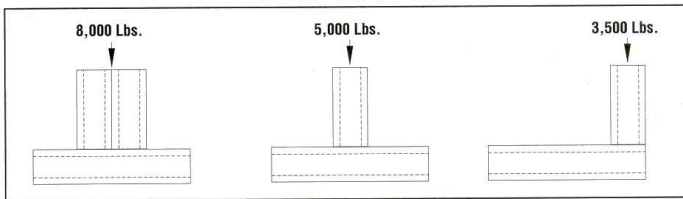

**Resistance to Slip** - 1,500 lbs. per bolt when 1/2" PS NS channel nuts are used.

**Pull Out Strength** - 2,000 lbs. per bolt when 1/2" PS NS channel nuts are used.

### PS 200 EH - Channel with Elongated Holes

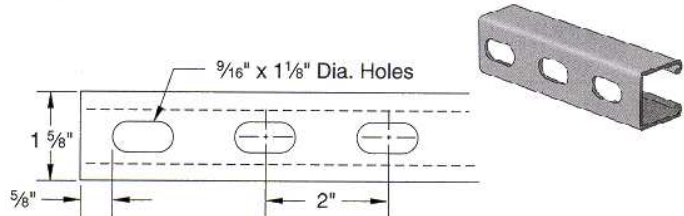

Weight: 185 lbs./100 ft.

### SUBMITTAL INFORMATION

CUSTOMER:		APPROVAL STAMP
PROJECT NAME:		
PROJECT NUMBER:	SECTION:	
PARAGRAPH:	OTHER:	



# PS 150 - STRUT CHANNEL (1 5/8 x 2 7/16 x 12 GA.)

411 BURNHAM ST.  
P.O. BOX 280186  
EAST HARTFORD, CT 06108  
TEL (860) 289-0285 FAX (860) 282-1487  
TOLL FREE 1-800-969-0285



**FINISH:**  PLAIN  PRE-GALVANIZED  PAINTED GREEN

**STOCK LENGTH:** 10' AND 20', OTHER LENGTHS ON REQUEST.

**NOTES:** COLUMN LOADS ARE FOR ALLOWABLE AXIAL LOADS AND MUST BE REDUCED FOR ECCENTRIC LOADING. FOR CONCENTRATED LOAD AT CENTER OF SPAN, DIVIDE UNIFORM LOAD BY 2 AND MULTIPLY CORRESPONDING DEFLECTION BY 0.8. THE TABLE BELOW IS BASED ON A SOLID CHANNEL SECTION.

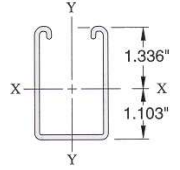
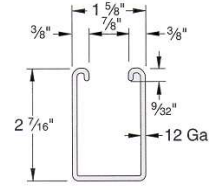
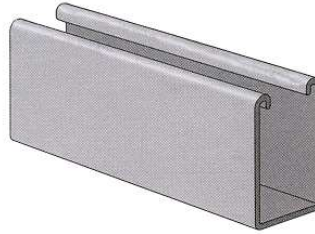

WEIGHT (IBS./100 FT.)	AREA OF SECTION (INCH <sup>2</sup> )	X-X AXIS			Y-Y AXIS		
		MOMENT OF INERTIA (INCH <sup>4</sup> )	SECTION MODULUS (INCH <sup>3</sup> )	RADIUS OF GYRATION (INCH)	MOMENT OF INERTIA (INCH <sup>4</sup> )	SECTION MODULUS (INCH <sup>3</sup> )	RADIUS OF GYRATION (INCH)
230	0.677	0.492	0.370	0.853	0.314	0.387	0.681

**MODULUS OF ELASTICITY: 29,000,000 PSI**

SPAN, OR COLUMN IN	MAX. LOAD OF COLUMN LOADED AT C.G. (K=1.0) LBS	STATIC BEAM LOAD (X-X AXIS)			
		TOTAL UNIFORM LOAD @25,000 PSI LBS	DEFLECTION @25,000 PSI IN	TOTAL UNIFORM LOAD @1/240 SPAN DEFLECTION LBS	TOTAL UNIFORM LOAD @ 1/360 SPAN DEFLECTION LBS
12	13,740	6,200 *	0.01	-	-
18	12,490	4,130	0.02	-	-
24	10,870	3,100	0.04	-	-
30	8,980	2,480	0.06	-	-
36	6,930	2,070	0.09	-	-
42	5,430	1,770	0.12	-	1,760
48	4,450	1,550	0.15	-	1,340
54	3,770	1,380	0.19	-	1,060
60	3,270	1,240	0.24	-	860
66	2,900	1,130	0.29	1,070	710
72	2,600	1,030	0.35	900	600
84	2,180	890	0.47	660	440
96	1,870	770	0.61	500	340
108	1,650	690	0.78	400	270
120	1,470	620	0.96	320	220

**FOR PIERCED CHANNELS,  
REDUCE BEAM LOAD  
VALUES AS FOLLOWS:**

PS-150-EH	15%
PS-150-S	15%
PS-150-H	10%
PS-150-K06	5%

FOR EXTRUDED ALUMINUM  
CHANNELS REDUCE BEAM  
LOAD VALUES 38%.

**\* BEARING MAY  
GOVERN CAPACITY.**

### PS 150 - Crush Loads

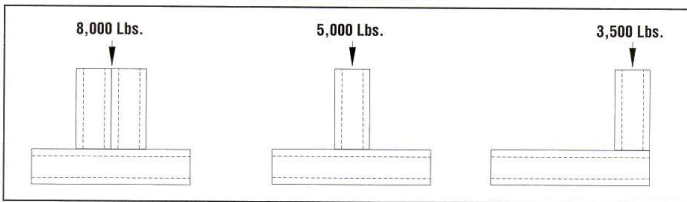

**Resistance to Slip** - 1,500 lbs. per bolt when 1/2" PS NS channel nuts are used.

**Pull Out Strength** - 2,000 lbs. per bolt when 1/2" PS NS channel nuts are used.

### PS 150 EH - Channel with Elongated Holes

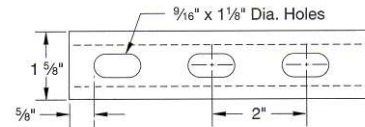
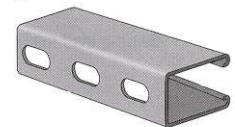

Weight: 242 lbs./100 ft.

### SUBMITTAL INFORMATION

SUBMITTAL INFORMATION		APPROVAL STAMP
CUSTOMER:		
PROJECT NAME:		
PROJECT NUMBER:	SECTION:	
PARAGRAPH:	OTHER:	



# PS 200 2T3 STRUT CHANNEL (1 5/8 x 1 5/8 x 12 GA.)

411 BURNHAM ST.  
P.O. BOX 280186  
EAST HARTFORD, CT 06108  
TEL (860) 289-0285 FAX (860) 282-1487  
TOLL FREE 1-800-969-0285



**FINISH:**  PLAIN  PRE-GALVANIZED  PAINTED GREEN  
 HOT DIPPED GALVANIZED

**STOCK LENGTH:** 10' AND 20', OTHER LENGTHS ON REQUEST.

**NOTES:** COLUMN LOADS ARE FOR ALLOWABLE AXIAL LOADS AND MUST BE REDUCED FOR ECCENTRIC LOADING. FOR CONCENTRATED LOAD AT CENTER OF SPAN, DIVIDE UNIFORM LOAD BY 2 AND MULTIPLY CORRESPONDING DEFLECTION BY 0.8. THE TABLE BELOW IS BASED ON A SOLID CHANNEL SECTION. FOR PIERCED SECTION, PS200 EH 2T3, REDUCE

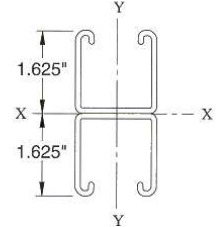
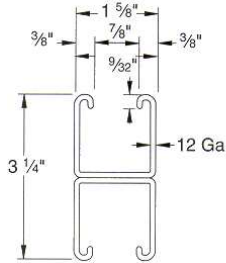
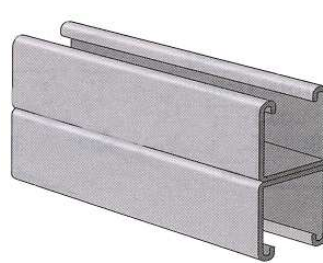

WEIGHT (IBS./100 FT.)	AREA OF SECTION (INCH <sup>2</sup> )	X-X AXIS			Y-Y AXIS		
		MOMENT OF INERTIA (INCH <sup>4</sup> )	SECTION MODULUS (INCH <sup>3</sup> )	RADIUS OF GYRATION (INCH)	MOMENT OF INERTIA (INCH <sup>4</sup> )	SECTION MODULUS (INCH <sup>3</sup> )	RADIUS OF GYRATION (INCH)
353	1.038	0.878	0.541	0.920	0.444	0.546	0.654

**MODULUS OF ELASTICITY: 29,000,000 PSI**

SPAN, OR COLUMN IN	MAX. LOAD OF COLUMN LOADED AT C.G. (K=1.0) LBS	STATIC BEAM LOAD (X-X AXIS)			
		TOTAL UNIFORM LOAD @25,000 PSI LBS	DEFLECTION @25,000 PSI IN	TOTAL UNIFORM LOAD @1/240 SPAN DEFLECTION LBS	TOTAL UNIFORM LOAD @ 1/360 SPAN DEFLECTION LBS
12	22,430	3,130 Ω	0.01	-	-
18	22,090	3,130 Ω	0.02	-	-
24	21,610	3,130 Ω	0.03	-	-
30	20,990	3,130 Ω	0.05	-	-
36	20,230	3,020	0.07	-	-
42	19,330	2,590	0.10	-	-
48	18,300	2,270	0.13	-	-
54	17,130	2,010	0.16	-	1,900
60	15,810	1,810	0.20	-	1,540
66	14,370	1,650	0.24	-	1,270
72	12,780	1,510	0.28	-	1,070
84	9,540	1,290	0.39	1,180	780
96	7,300	1,130	0.50	900	600
108	5,700	1,010	0.64	710	470
120	4,670	910	0.79	580	380

**PS 200 EH 2T3** – Channel with Elongated Holes

**Ω LOAD LIMITED BY  
SPOT WELD SHEAR.**

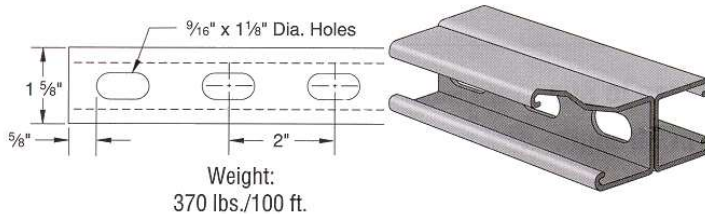

## SUBMITTAL INFORMATION

CUSTOMER:		APPROVAL STAMP
PROJECT NAME:		
PROJECT NUMBER:	SECTION:	
PARAGRAPH:	OTHER:	



# PS 150 2T3 STRUT CHANNEL (1 5/8 x 4 7/8 x 12 GA.)

411 BURNHAM ST.  
P.O. BOX 280186  
EAST HARTFORD, CT 06108  
TEL (860) 289-0285 FAX (860) 282-1487  
TOLL FREE 1-800-969-0285



**FINISH:**  PLAIN  PRE-GALVANIZED  PAINTED GREEN

**STOCK LENGTH:** 10' AND 20', OTHER LENGTHS ON REQUEST.

**NOTES:** COLUMN LOADS ARE FOR ALLOWABLE AXIAL LOADS AND MUST BE REDUCED FOR ECCENTRIC LOADING. FOR CONCENTRATED LOAD AT CENTER OF SPAN, DIVIDE UNIFORM LOAD BY 2 AND MULTIPLY CORRESPONDING DEFLECTION BY 0.8. THE TABLE BELOW IS BASED ON A SOLID CHANNEL SECTION.

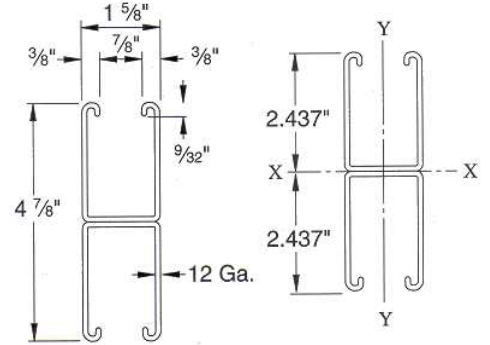
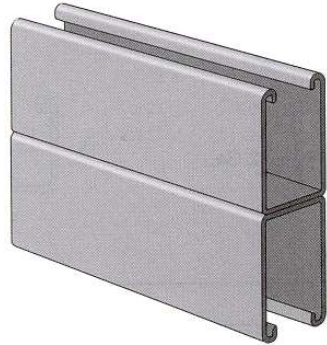

WEIGHT (LBS./100 FT.)	AREA OF SECTION (INCH <sup>2</sup> )	X-X AXIS			Y-Y AXIS		
		MOMENT OF INERTIA (INCH <sup>4</sup> )	SECTION MODULUS (INCH <sup>3</sup> )	RADIUS OF GYRATION (INCH)	MOMENT OF INERTIA (INCH <sup>4</sup> )	SECTION MODULUS (INCH <sup>3</sup> )	RADIUS OF GYRATION (INCH)
460	1.353	2.638	1.083	1.396	0.628	0.773	0.681

**MODULUS OF ELASTICITY: 29,000,000 PSI**

SPAN, OR COLUMN IN	MAX. LOAD OF COLUMN LOADED AT C.G. (K=1.0) LBS	STATIC BEAM LOAD (X-X AXIS)			
		TOTAL UNIFORM LOAD @25,000 PSI LBS	DEFLECTION @25,000 PSI IN	TOTAL UNIFORM LOAD @1/240 SPAN DEFLECTION LBS	TOTAL UNIFORM LOAD @ 1/360 SPAN DEFLECTION LBS
12	29,720	4,680 Ω	0.01	-	-
18	28,860	4,680 Ω	0.01	-	-
24	28,280	4,680 Ω	0.02	-	-
30	27,530	4,680 Ω	0.03	-	-
36	26,620	4,680 Ω	0.05	-	-
42	25,540	4,680 Ω	0.06	-	-
48	24,300	4,540	0.08	-	-
54	22,890	4,030	0.11	-	-
60	21,320	3,630	0.13	-	-
66	19,580	3,300	0.16	-	-
72	17,680	3,030	0.19	-	-
84	13,500	2,590	0.26	-	2,350
96	10,340	2,270	0.34	-	1,800
108	8,170	2,020	0.43	-	1,420
120	6,610	1,820	0.52	1,730	1,150

**Ω LOAD LIMITED BY SPOT WELD SHEAR**

### SUBMITTAL INFORMATION

CUSTOMER:		APPROVAL STAMP	
PROJECT NAME:			
PROJECT NUMBER:	SECTION:		
PARAGRAPH:	OTHER:		