



411 BURNHAM ST.
 P.O. BOX 280186
 EAST HARTFORD, CT 06108
 TEL (860) 289-0285 FAX (860) 282-1487
 TOLL FREE 1-800-969-0285

PS 624 TWO-HOLE CLOSED ANGLE CONNECTOR



MATERIAL: STEEL

ALL POWER-STRUT FITTINGS ARE FORMED IN PUNCH PRESS DIES FROM MILD, PICKLED AND OILED, BAR OR STRIP STEEL. PLAIN OR ELECTRO-GALVANIZED FITTINGS MEET THE REQUIREMENTS FOR ASTM A-575 AND A-576, OR ASTM A-36.

STANDARD DIMENSIONS: STANDARD DIMENSIONS ON ALL FITTINGS ARE AS FOLLOWS EXCEPT WHERE OTHERWISE INDICATED.

FITTING THICKNESS: 1/4"

FITTING WIDTH: 1 5/8"

HOLE DIAMETER: 9/16"

HOLE SPACING: 1 7/8" ON CENTERS AND 13/16" FROM ENDS.

FINISH:

- PAINTED GREEN ELECTRO-GALVANIZED
- HOT DIPPED GALVANIZED PVC COATED*

*PVC COATING: BLACK POLY VINYL CHLORIDE RESIN COATED TO A MAX THICKNESS OF 20 MILS

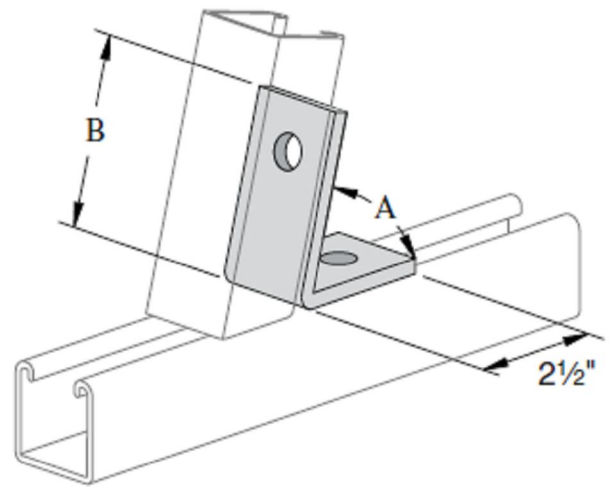

"B" In.	"A" Angle
3"	37 1/2°
3 1/8"	45°
3 1/16"	52 1/2°
3 1/8"	60°
3 1/8"	67 1/2°
3 3/16"	75°
3 3/16"	82 1/2°

SUBMITTAL INFORMATION

CUSTOMER:		APPROVAL STAMP
PROJECT NAME:		
PROJECT NUMBER:	SECTION:	
PARAGRAPH:	OTHER:	