



PS 633 TWO HOLE OPEN ANGLE CONNECTOR

411 BURNHAM ST.
P.O. BOX 280186
EAST HARTFORD, CT 06108
TEL (860) 289-0285 FAX (860) 282-1487
TOLL FREE 1-800-969-0285



MATERIAL:

ALL POWER-STRUT FITTINGS ARE FORMED IN PUNCH PRESS DIES FROM MILD, PICKLED AND OILED, BAR OR STRIP STEEL. PLAIN OR ELECTRO-GALVANIZED FITTINGS MEET THE REQUIREMENTS FOR ASTM A-575 AND A-576, OR ASTM A-36.

STANDARD DIMENSIONS:

STANDARD DIMENSIONS ON ALL FITTINGS ARE AS FOLLOWS EXCEPT WHERE OTHERWISE INDICATED.
 FITTING THICKNESS: 1/4"
 FITTING WIDTH: 1 5/8"
 HOLE DIAMETER: 9/16"
 HOLE SPACING: 1 7/8" ON CENTERS AND 13/16" FROM ENDS.

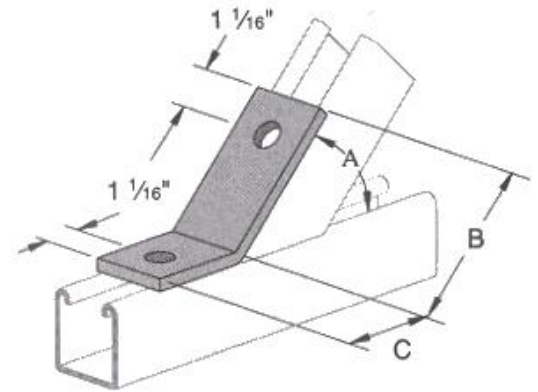

WEIGHT/100 PCS: 58LBS

FINISH:

- PAINTED GREEN
- ELECTRO-GALVANIZED

"A" DEGREE	"B" IN.	"C" IN.
82 1/2°	3 9/16	1 11/16
75°	3 9/16	1 11/16
67 1/2°	3 1/2	1 3/4
60°	3 3/8	1 7/8
52 1/2°	3 1/4	2 1/16
45°	3	2 5/16
37 1/2°	3 1/2	1 13/16
37 1/2°	2 11/16	2 5/8
30°	3 1/4	2 1/16
22 1/2°	3 5/16	2 1/16
15°	3 5/16	2 1/16
7 1/2°	3 5/16	2 1/16

SUBMITTAL INFORMATION

CUSTOMER:		APPROVAL STAMP
PROJECT NAME:		
PROJECT NUMBER:	SECTION:	
PARAGRAPH:	OTHER:	

REV: A

2008