

PIPE ROLLERS & ROLLER SUPPORTS NEFCO FIG #N280S

411 BURNHAM ST.
P.O. BOX 280186
EAST HARTFORD, CT 06108
TEL (860) 289-0285 FAX (860) 282-1487
TOLL FREE 1-800-969-0285

EMPIRE INDUSTRIES, INC. FIG. #279S
ERICO FIG. #617
TOLCO FIG. #327

MATERIAL: STEEL WITH CAST IRON ROLLER

FINISH: PLAIN ELECTRO-PLATED HOT DIPPED GALVANIZED

SERVICE: DESIGNED FOR SUPPORT OF PIPE WITH LONGITUDINAL MOVEMENT.

APPROVALS: COMPLIES WITH FEDERAL SPECIFICATION WW-H-171E TYPE 45 AND MANUFACTURERS' STANDARDIZATION SOCIETY SP-69

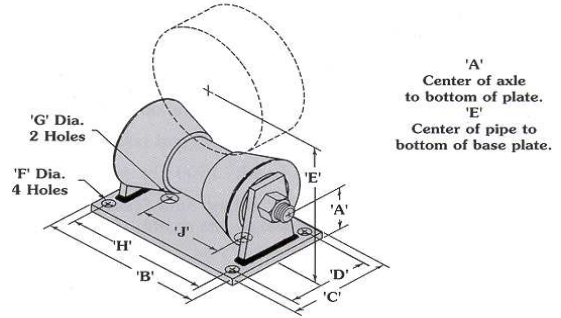

NOMINAL PIPE SIZE	A	B	C	D	E
2	1 3/4	8 3/8	6	4	3 11/16
2 1/2	1 3/4	8 3/8	6	4	3 15/16
3	1 3/4	8 3/8	6	4	4 1/4
3 1/2	1 3/4	8 3/8	6	4	4 1/2
4	2 1/16	9 7/8	6	4 1/4	5
5	2 1/16	9 7/8	6	4 1/4	5 9/16
6	2 1/16	9 7/8	6	4 1/4	6 1/16
8	3 7/16	8 5/8	8	5	8 13/16
10	3 7/16	8 5/8	8	5	9 7/8
12	3 7/8	10 15/16	8	6	11 7/16
14	3 7/8	10 15/16	8	6	12 1/16
16	4 1/4	12 3/8	10	6 1/2	13 5/8
18	4 1/4	12 3/8	10	6 1/2	14 11/16
20	4 1/4	12 3/8	10	6 1/2	15 11/16
24	4 3/8	13 1/2	10	6 1/2	17 11/16
30	5 1/8	17	10 3/4	8	21 3/4

DIA. F	DIA. G	H	I	DESIGN LOAD LBS.	WT./C LBS.
1/2	1	6 3/8	3 7/16	390	508
1/2	1	7 7/8	4 11/16	950	631
5/8	1	7	4	2100	1271
3/4	1	9 1/16	5 3/4	3075	1994
13/16	1	10 1/4	6 3/4	4980	3423
13/16	1	11 3/8	7 1/2	6100	4710
1 1/16	1	14 1/4	10	7500	7132

SUBMITTAL INFORMATION

CUSTOMER:		APPROVAL STAMP
PROJECT NAME:		
PROJECT NUMBER:	SECTION:	
PARAGRAPH:	OTHER:	

REV: C JULY 2007